

CALCOLO SUPERFICIE LORDA DI PAVIMENTO (S.L.P.) -RILIEVO-

PIANO TERRA ATTUALE				
P.T	1	$(2,80+2,53)/2 \times 3,00$	= m ²	8,01 +
P.T	2	$(5,19 \times 4,31)/2$	= m ²	11,18 +
P.T	3	$(4,62 \times 4,56)/2$	= m ²	10,53 +
P.T	4	$8,86 \times 4,55$	= m ²	40,13 +
P.T	5	$(0,86+0,49)/2 \times 4,54$	= m ²	3,06 +
P.T	6	$(3,85 \times 3,62)$	= m ²	13,93 =
			= m ²	<u>86,84</u> m ² 86,84

PIANO PRIMO ATTUALE				
P.P	7	$(5,19 \times 4,31)/2$	= m ²	11,18 +
P.P	8	$(4,62 \times 4,56)/2$	= m ²	10,53 +
P.P	9	$(8,22 \times 4,55)$	= m ²	37,40 =
			= m ²	<u>59,11</u> = m ² 59,11
			S.L.P TOTALE	= m ² 145,95
S.L.P AMMESSA CON PIANO DI RECUPERO			145,95 + 10% = m² 160,54	

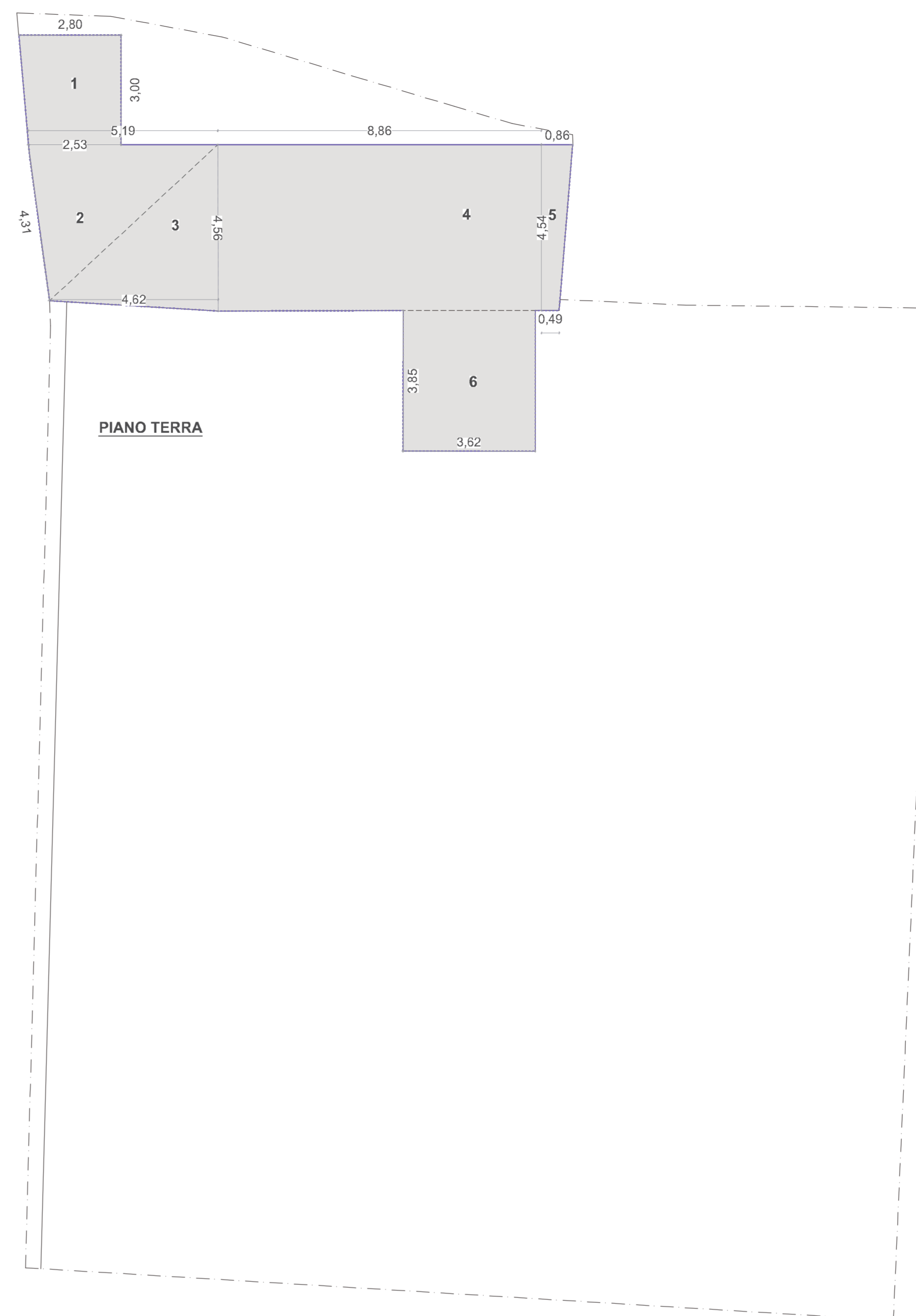
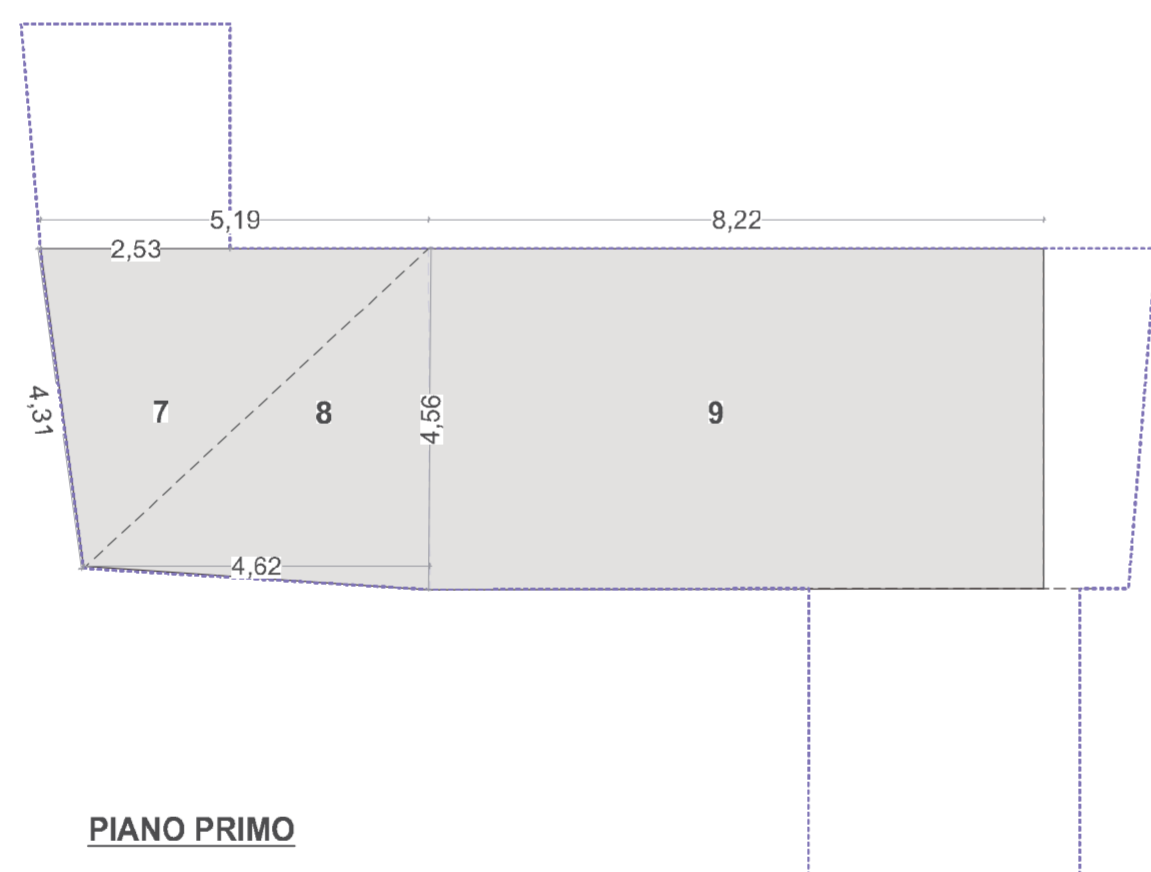

Committente:
Sig. Guido Gualina
 Via Iseo 58-Erbusco-(Bs)
 C.F. GLN GDU 80E10C618Q

Progetto
 PIANO DI RECUPERO DI
 FABBRICATO AD USO
 RESIDENZIALE IN VIA ARICI

Id catastale
 N.C.T. Foglio 7 Mappale 142-SUB 2
 Comune di Rovato

Oggetto
**RILIEVO:
 CALCOLO S.L.P.**

Tav.

09

Data Agg.
Giugno 2021

Scala:
1:100

Progettista:

Arch. Domenico Ciusa
 Via Costituzione, 22-25038 Rovato Bs
 cell. 335-43 30 725
 e-mail ciusadomenico@gmail.it
 e-mail pec.domenico.ciusa@archworldpec.it



This document was created with Win2PDF available at <http://www.win2pdf.com>.
The unregistered version of Win2PDF is for evaluation or non-commercial use only.
This page will not be added after purchasing Win2PDF.